

KNX-DALI Gateway



Datasheet

KNX-DALI Gateway

KNX to DALI and
DALI to KNX gateway,
full multi-master capability

Art. Nr. 89453899



KNX-DALI Gateway Interface

Overview

- **Dali multi-master capable**
- **up to 63 addressable DALI devices**
- Use of broadcast, individual addresses and groups is possible
- **KNX color control RGB, RGBW, HSV, XY (DT8)**
- **color temperature control (Tunable White)**
- light control of various device types (DT0, DT2, DT3, DT4, DT6)
- recall of DALI scenes (0...15)
- KNX communication objects for relative and absolute control
- Color control via standard KNX objects and **percentage values**
- KNX communication objects for light status
- **Luminaire failure detection**
- Support of Lunatone modes Color&Dim, Balance&Dim, Dim2Warm
- alternative color control with DT6 (RGB, RGBW, Tc)
- Luminaire test for system set up
- Product database for ETS 5
- easy configuration via Lunatone DALI USB interface and free DALI-Cockpit Software tool
- **DALI-2 Event** conversion to KNX
- **DALI-2** and KNX certified



Specification, Characteristics

type	KNX-DALI Gateway
article number	89453899
input: KNX	
input type	KNX / TP
input voltage range	DC 21...32V SELV
max. input supply current	6mA
max. power consumption	150mW
input: DA, DA	
input type	DALI
marking terminals	DA DA
input voltage range	10...22,5V
max. current consumption DALI	3mA
insulation data:	
impulse voltage category	II
pollution degree	2
rated insulation voltage	250V
insulation DALI (DA,DA) / KNX(+,-)	reinforced isolation

KNX(+,-) / DALI (DA,DA)	
insulation test voltage DALI-output/mains	3000Vac

environmental conditions:

storing and transportation temperature	-20°C... +75°C
operational ambient temperature	-20°C ... +60°C
rel. humidity, none condensing	15%...90%

general data:

dimensions (l x w x h)	98mm x 17,5mm x 56mm
mounting	Din Rail
expected lifetime @ ta = 25°C	50.000h
protection degree housing	IP40
protection degree terminals	IP20

terminals DALI:

connection type	screw connector
wire size solid core	0,5 ... 2,5 mm ² (AWG20 ... AWG14)
wire size fine wired	0,5 ... 2,5 mm ² (AWG20 ...AWG14)
wire size using wire end ferrule	0,25 ... 1,5 mm ²
stripping length	7 mm / 0,27 inch
locking torque	0,5Nm

General description

The gateway connects the KNX world with the DALI world. It is DALI-2 and KNX certified and multi-master capable (DALI-2 standard).

The device supports color temperature control (CW-WW), color control (RGB, RGBW) as well as the control of other light sources (DT0, DT2, DT3, DT4, DT6) and DALI-2 event messages.

There are two options to control **the color temperature CW-WW**:

- 1) KNX communication objects
- 2) Percentage values: The color temperature is automatically tracked via the brightness value. In this case, a table is used to define the color temperature.

Color control RGB, RGBW can be realized with:

- 1) KNX communication objects
- 2) Percentage values: A table is used to

translate percentage specifications into color values.

It is possible to use predefined translation tables as well as defining a new table with 16 entries.

Usually the DALI Device Type 8 (DT8) is used for color control. However, the gateway also offers the option to implement color control using DT6 ballasts.

DALI **scene recalls** are possible with KNX communication objects for scenes. The scenes can be assigned with the help of a table. The functionality of the connected DALI ballasts/operating devices can be tested easily.

DALI-2 events can be provided on KNX with the DALI KNX gateway. Depending on the

event information, it is possible to choose between different communication objects.

The DALI-KNX Gateway can be configured with a product database for ETS5.

The DALI system can be configured with a Lunatone DALI USB interface and the free Software tool DALI-Cockpit. When using the DALI-Cockpit Software, the PC must be connected to the DALI bus via a suitable interface module (e.g. DALI USB, DALI 4Net, DALI SCI RS232).

The gateway is supplied by the DALI system as well as the KNX bus. A DALI bus power supply (e.g. DALI PS Art. Nr.: 24033444) is required.

Installation

- 1.) Mount the Gateway on a DIN rail
- 2.) Connect the Gateway according to the drawing (Fig.1 typical application)
- 3.) Activate the KNX and DALI bus supply.

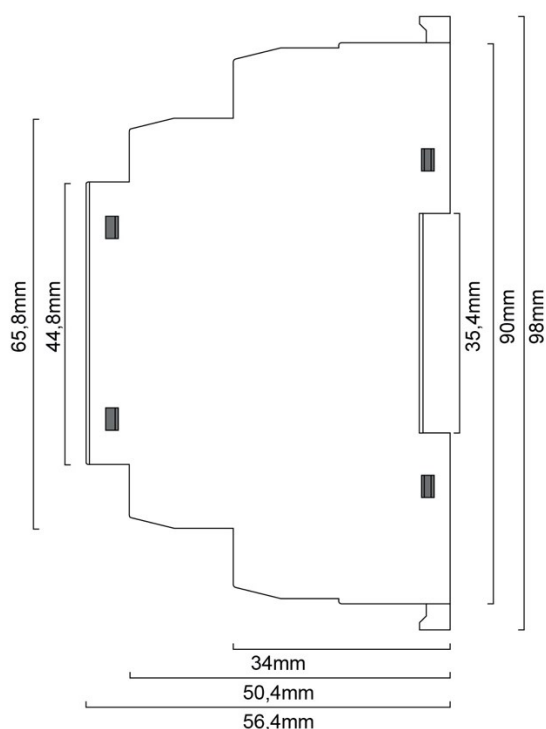

dimensions KNX-DALI Gateway
Art.Nr.: 89453899

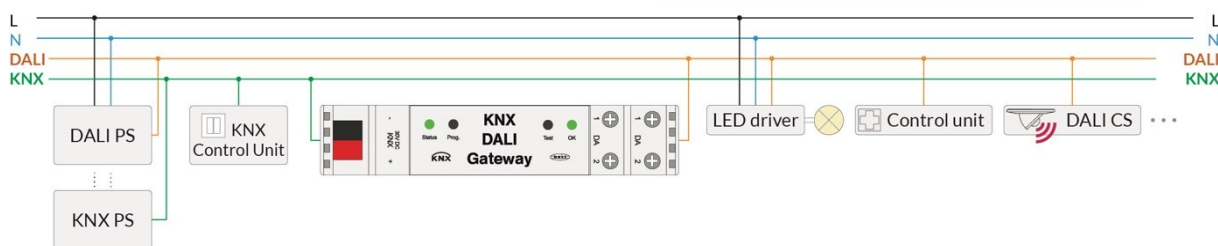
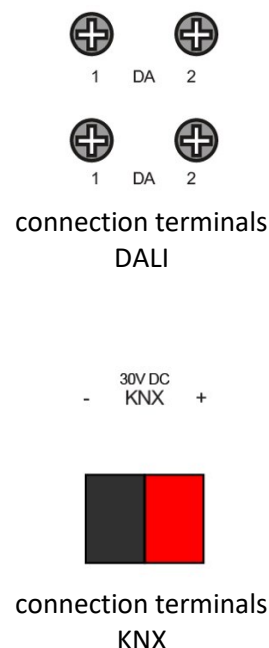
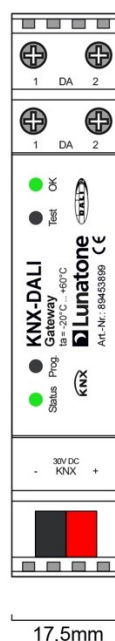

Fig.1 typical application

Set-up the Software

- 1.) Start ETS5 and load the Gateway's product database.
- 2.) Assign KNX address to the Gateway:
-> When requested, press the "Prog. button" on the device housing. If the address has been assigned successfully, the red LED will turn off.
- 3.) Start the Lunatone DALI Cockpit Software and make the desired configurations for the DALI System.
- 4.) Configure the required gates in the ETS (function, DALI address).
- 5.) Load the settings made in the ETS into the Gateway.

ETS (KNX configuration Software)

An ETS (version ETS 5) product database for the gateway is available. Download link for ETS product database:
<https://www.lunatone.com/en/downloads-a-z/>

All necessary settings for the KNX system can be made using the ETS. For larger projects, it can be useful to rename the gates and enter the used DALI addresses - this can increase clarity in the product database. See Fig.2

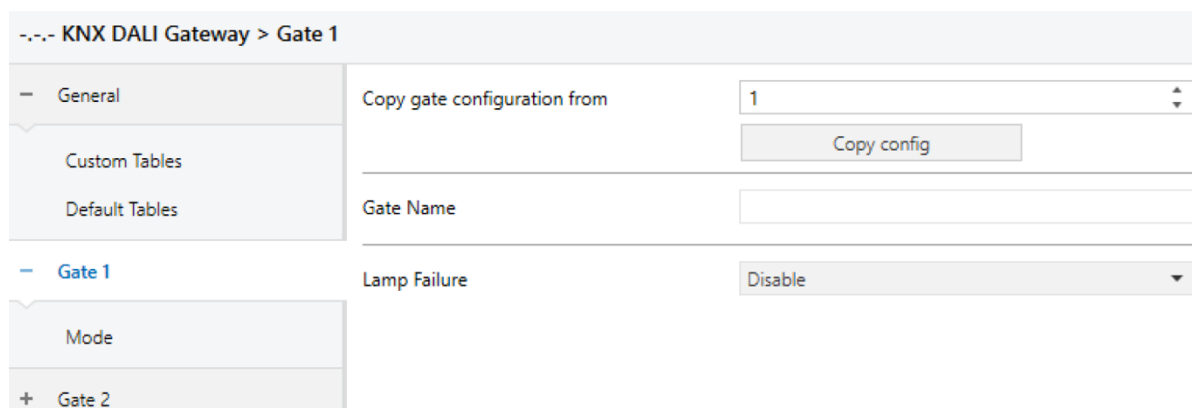

Fig.2 Gate Settings ETS

DALI Cockpit

DALI Cockpit is a configuration software developed by Lunatone for DALI devices (Windows operating system). Requirement: Interface to the DALI bus e.g. DALI USB
Art.Nr.: 24138923-HS

Download link for DALI Cockpit Software:
<https://www.lunatone.com/en/product/dali-cockpit/>

- The following DALI settings can be made:
- Assignment of DALI addresses
 - definition of groups
 - definition of scenes
 - configuration of the DALI operating devices
 - setting Lunatone operating modes (Dim2Warm, Balance&Dim, Color&Dim)
 - defining fade time
 - saving and loading DALI configurations
 - sending DALI commands manually

DALI multi-master

The gateway supports the DALI multi-master operation. This makes it possible to use local control devices (with application controller) on the DALI bus.

Figure 3 shows an exemplary DALI system with 2 groups (yellow rectangles). The light actuators of group 2 are switched with 2 DALI switches and a DALI sensor. In group 1 the light actuators can also be switched with a KNX switch as well as a DALI switch and sensor.

The gateway records all changes to the DALI bus and sends status messages (in the event of a change) to the KNX devices. This means that the current light status is known to the KNX switch, even if the light is switched using a DALI switch. Of course, this principle can be used not only for switching but also for color control.

The installation in figure 2 furthermore includes a KNX switch for central switching of group 1 and 2.

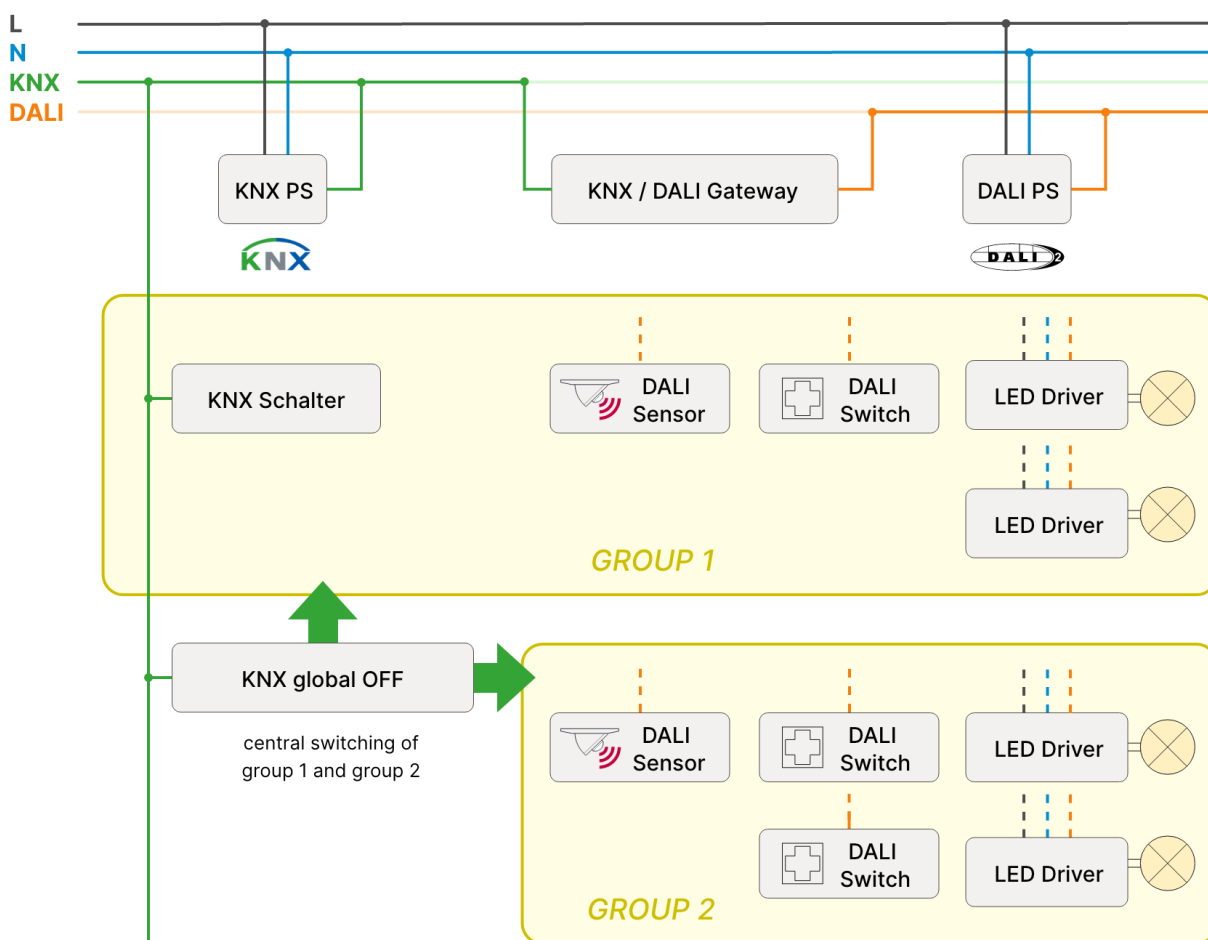

Fig.3 application with multi-master

Assigning DALI addresses

With the DALI Cockpit Software all devices on the DALI bus are automatically assigned an individual address. Furthermore, up to 16 groups can be defined and recalled with group

addresses.

With broadcast, all devices are controlled simultaneously, if this is the preferred control method a configuration with DALI Cockpit is not required.

With group or broadcast addressing the

assigned devices will receive DALI commands simultaneously, hence a synchronous lighting control can be realized.

In the product database of the KNX gateway (ETS KNX Software) 63 gates are available. To

each of the gates a DALI address can be assigned. It is possible to select individual addresses, group addresses or broadcast. Assigning addresses to the gates will allow the KNX System to control the DALI System.

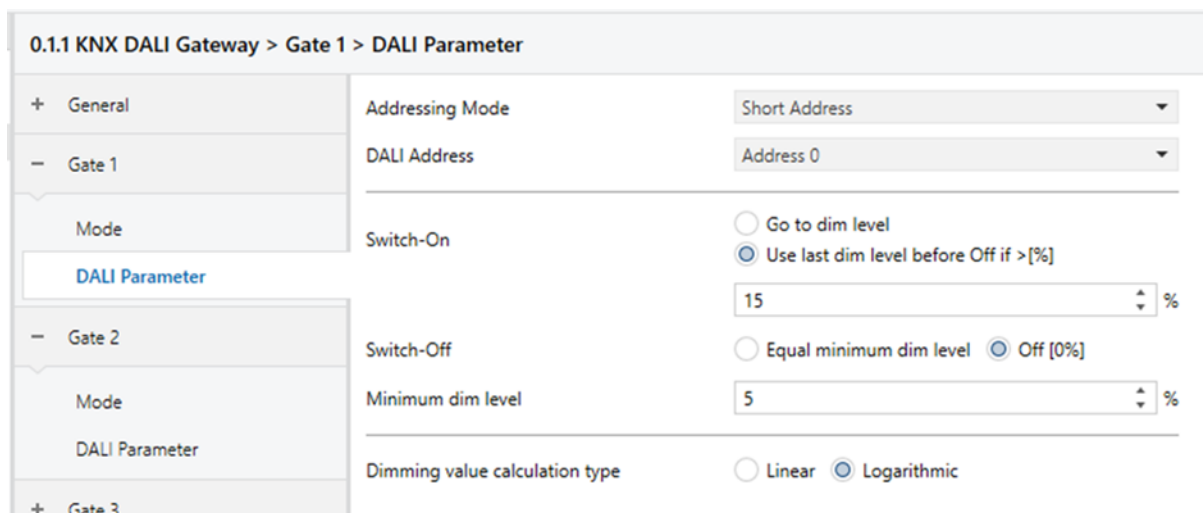

Fig.4 Gate Settings ETS: DALI Parameter

DALI Scenes

16 scenes can be defined in a DALI system. When a scene is recalled, all devices adopt the set scene values. Scenes can be defined using the DALI Cockpit Software.

DALI Device Types

In the DALI standard, devices are divided into different types. The following device types are supported by the gateway:

- DT0 fluorescent lamps
- DT2 discharge lamps
- DT3 low voltage halogen lamps
- DT4 incandescent light bulbs
- DT6 single color LEDs - 1 channel
- DT8 color management of Tunable White CW-WW and color RGB / RGBW LEDs

Gateway start-up (reset) behavior

There are two possible start-up behaviors:

- recall of a predefined values. Values can be defined with the ETS, at start-up the status communication objects are automatically sent.
- no action

These options are available in the ETS product database for each gate.

DALI luminaire tests

The gateway offers the option to send lamp errors messages as status objects to the KNX devices. To do this, the lamp status of DALI devices has to be queried. In the ETS product database you can select whether the query should be carried out cyclically and / or when the device is switched on.

 Attention: If group addressing or broadcast is used, it will show that lamps are faulty but not which ones.

 Attention: LED on device housing:
LED = ON -> test active
LED = OFF -> test inactive

DALI commissioning test

The commissioning test can be activated and deactivated with the test button on the device. Several test variants are available. The following options can be selected in the product database:

Test option	description
Broadcast	All lamps on the DALI bus are switched on / off cyclically.
Single Gate	A single gate is tested: All lamps assigned to the selected gate are switched on / off cyclically. (Assigning lamps to gates is possible with the ETS product database. See page 6.)
Manual Gate Selection	The test button on the device can be used to select the gate which should be tested. Only gates that have assigned functions can be selected. Every second button press (when turning off) switches the gate. All lamps assigned to the selected gate are switched on / off cyclically. The first gate can be selected prematurely by pressing the test button for 3 seconds. tabel.1 test options

DT6 as an alternative to DT8

Lunatone DT8 LED dimmers are used to control the brightness and color temperature or color of Tunable White CW-WW, RGB or RGBW capable luminaires. The devices are DALI Device Type 8 (DT8), which means only one DALI address is needed to control up to 4 outputs.

DT8 operating devices can be replaced by DT6 operating devices.

Lunatone offers DT6 LED dimmers with up to 4 separately controllable channels. Each channel has its own DALI address, to receive commands for the connected LED strings.

The color/ tunable white adjustment might not be as synchronously as with DT8 operating devices: With DT8, all color values are transferred and only executed after a dedicated command. When using DT6, the DALI commands are processed in order of transmission.

To use DT6 for Tunable White control a 2 Channel DT6 device is needed, one channel for cold white, one for warm white LED string. See Fig. 5.

For color control RGB (W) three or four channels are required, one for each color.

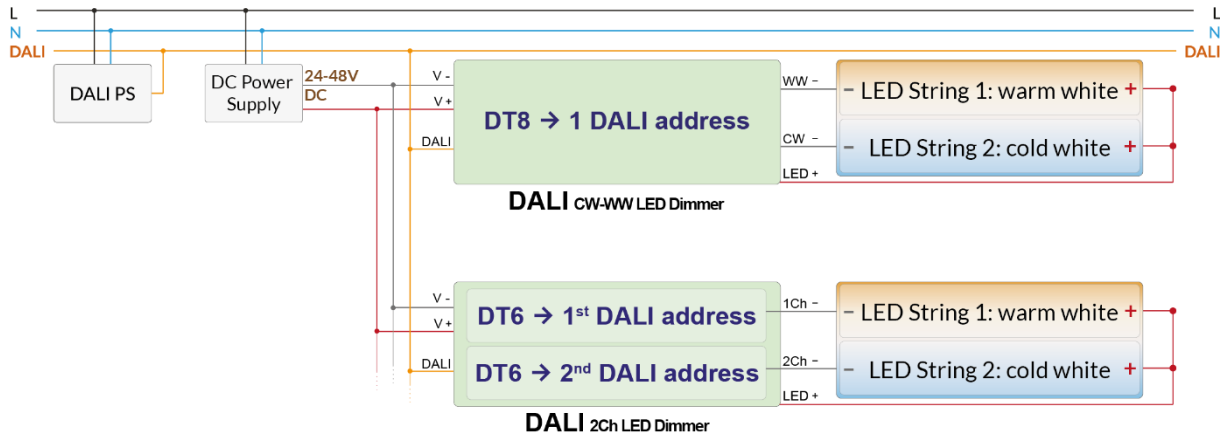

Fig.5 DT8 vs DT6 control of Tunable White (CW-WW)

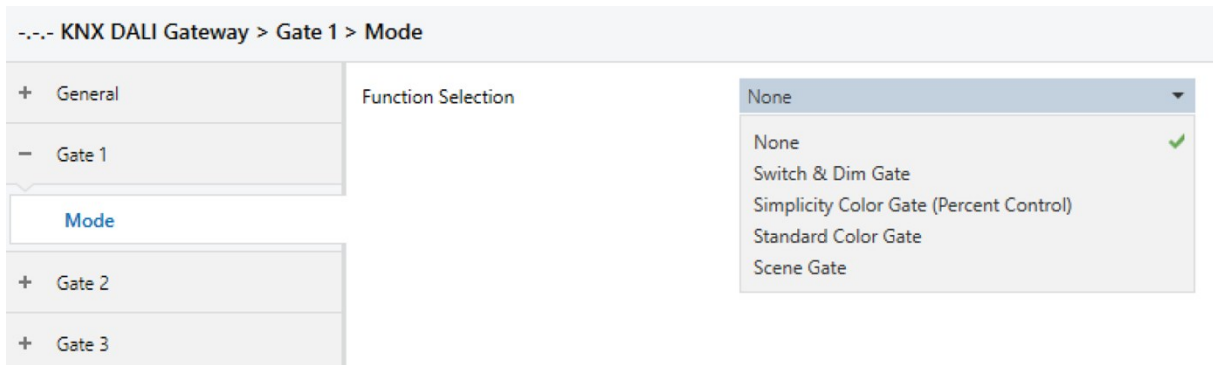
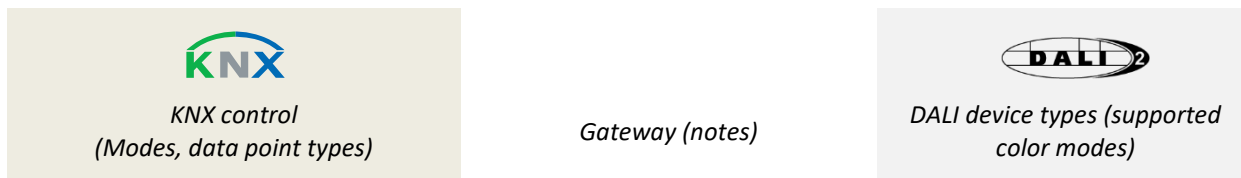

Fig.6 Gate Settings ETS: select Gate Type

Simplicity Color Gates:

These gates are specially designed to set color / color temperature and brightness with simple KNX buttons, the color setting is made using percentage values. Table 2 lists the

available options. Conversion parameters can be set in the ETS. The overview also shows the necessary data point types and compatible DT8, DT6 color display modes.



Control: color / brightness separately

<p>Option 1 - (absolute):</p> <ul style="list-style-type: none"> • Color: DPT 5.001 (0... 100%) • Brightness: DPT 5.001 (0... 100%) • Switching: DPT 1.001 (On / Off) 	<p>Color translation: 2 predefined tables, 1 individual table</p>	<p>DALI - DT8 Color display: XY coordinates</p>
<p>Option 2 - (relative):</p> <ul style="list-style-type: none"> • Color: DPT 1.007 (incr./decr.) • Brightness: DPT 1.007 (incr./decr.) • Switching: DPT 1.001 (On/Off) 	<p>Lunatone Color & Dim: 2 DALI addresses fixed table</p>	<p>DALI - DT8 Color display: RGBWAF</p> <p>DALI - DT6 3x1 channel DT6 3 DALI addresses</p> <p>Lunatone DT8 Operating mode: Colour&Dim</p>

Control: color temperature / brightness separately

<p>Option 1 - (absolute):</p> <ul style="list-style-type: none"> • Color temp.: DPT 5.001 (0...100%) • Brightness: DPT 5.001 (0...100%) • Switching: DPT 1.001 (On/Off) 	<p>Temperature translation: 2 predefined tables, 1 individual table</p>	<p>DALI - DT8 Color display: Tc</p>
<p>Option 2 - (relative):</p> <ul style="list-style-type: none"> • Color temp.: DPT 1.007 (incr./decr.) • Brightness: DPT 1.007 (incr./decr.) • Switching: DPT 1.001 (On/Off) 	<p>DT6: 2 DALI addresses for warm / cold light</p> <p>Lunatone Balance & Dim: 2 DALI addresses fixed table</p>	<p>DALI - DT8 Color display: XY coordinates</p> <p>DALI - DT6 2x1 channel DT6 / 2 channel DT6 2 DALI addresses</p> <p>Lunatone DT6 2 channel Operating mode: Balance&Dim</p>

Control: brightness, color temperature automatically

<p>Option 1 - (absolute):</p> <ul style="list-style-type: none"> Brightness: DPT 5.001 (0...100%) Switching: DPT 1.001 (On/Off) 	<p>The brightness can be set with a simple KNX switch button. The color temperature is set depending on the brightness. (Behavior lightbulb)</p>	<p>DALI - DT8 Color display: Tc</p>
<p>Option 2 - (relative):</p> <ul style="list-style-type: none"> Brightness: DPT 1.007 (incr./decr.) Switching: DPT 1.001 (On/Off) 		<p>DALI - DT8 Color display: XY coordinates</p>
		<p>DALI – DT6 2x1 channel DT6 / 2 channel DT6 2 DALI addresses</p>
		<p>Lunatone DT6 2 channel Operating mode: Dim2Warm</p>

table 2. Simplicity Color Gates

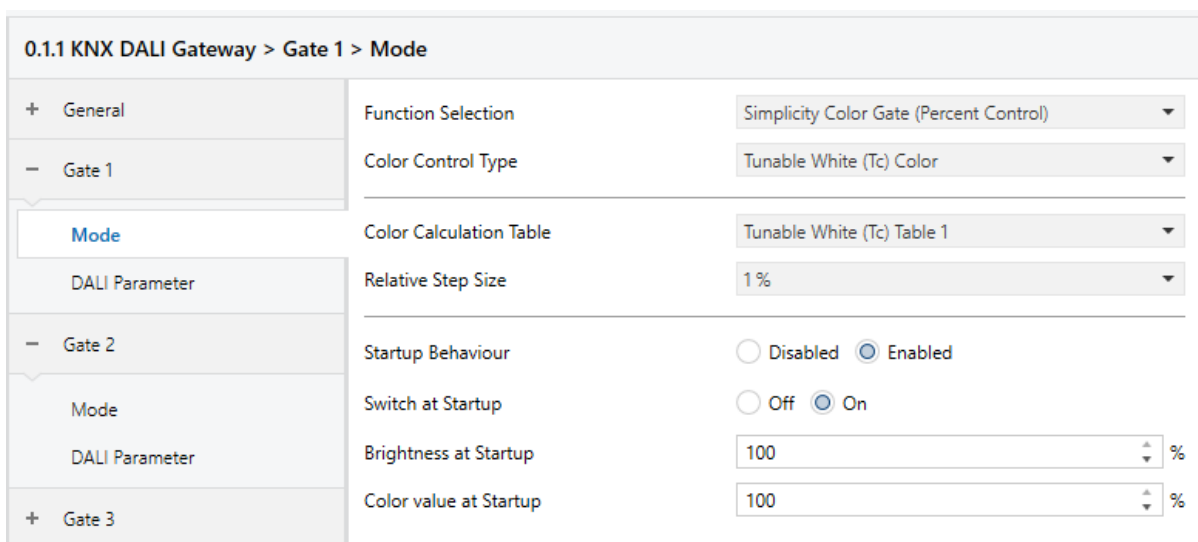

Fig.7 Gate Settings ETS: Tab “Mode” for Simplicity Color Gate **Tunable White**





Abb.8 Gate Settings ETS: Tab “DALI Parameters” for Simplicity Color Gate

Standard Color Gates

The control is implemented via the data point types for color control specified in KNX. Table 3 lists the available options:

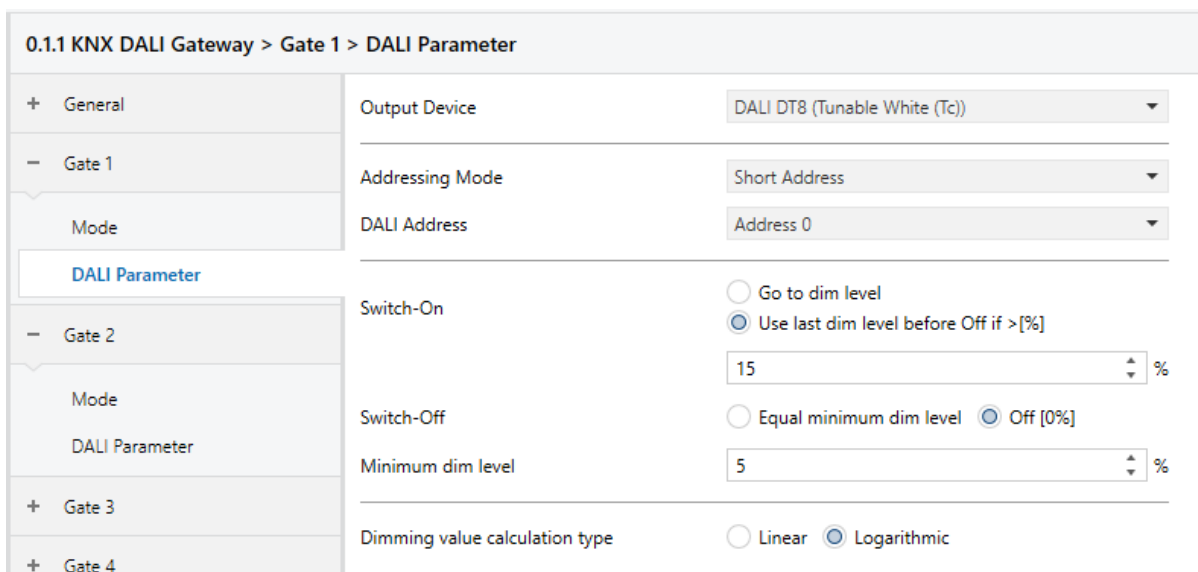
 KNX control (Modes, data point types)	Gateway (notes)	 DALI device types (supported color modes)
XY color control		
Option 1: <ul style="list-style-type: none"> • color x: DPT 7.001 (0...65.535) • color y: DPT 7.001 (0...65.535) • Brightness: DPT 3.007 (B1U3) • Switching: DPT 1.001 (On/Off) 	The XY color values and the brightness values are converted into a DT8 DALI command sequence.	DALI - DT8 Color display: XY coordinates
Option 2: <ul style="list-style-type: none"> • color xy: DPT 242.600 () • Brightness: DPT 3.007 (B1U3) • Switching: DPT 1.001 (On/Off) 		
Tc color control		
Option 1: <ul style="list-style-type: none"> • Tc: DPT 7.600 (Color Temp.) • Brightness: DPT 3.007 (B1U3) • Switching: DPT 1.001 (On/Off) 	The color temperature values and the brightness values are converted into a DT8 DALI command sequence.	DALI - DT8 Color display: Tc
Option 2: <ul style="list-style-type: none"> • Tc: DPT 5.001 (0...100%) • Brightness: DPT 1.007 (incr./decr.) • Switching: DPT 1.001 (On/Off) 		DALI – DT6 2x1 channel DT6 / 2 channel DT6 2 DALI addresses
RGB color control		
Option 1: <ul style="list-style-type: none"> • red: DPT 5.001 (0...100%) • green: DPT 5.001 (0...100%) • blue: DPT 5.001 (0...100%) • Brightness: DPT_3.007 (B1U3) • Switching: DPT 1.001 (On/Off) 	The RGB color values and the brightness values are converted into a DALI DT8 command sequence.	DALI - DT8 Color display: RGBWAF
Option 2: <ul style="list-style-type: none"> • red: DPT 3.007 (B1U3) • green: DPT 3.007 (B1U3) • blue: DPT 3.007 (B1U3) • Brightness: DPT_3.007 (B1U3) • Switching: DPT 1.001 (On/Off) 		DALI - DT6 3(4)x1 channel DT6 / 3(4) channels 3(4) DALI addresses
Option 3: <ul style="list-style-type: none"> • RGB: DPT 232.600 (Color RGB) • Brightness: DPT 3.007 (B1U3) 		

RGBW color control

<p>Option 1:</p> <ul style="list-style-type: none"> • red: DPT 5.001 (0...100%) • green: DPT 5.001 (0...100%) • blue: DPT 5.001 (0...100%) • white: DPT 5.001 (0...100%) • Brightness: DPT_3.007 (B1U3) • Switching: DPT 1.001 (On/Off) 	<p>The RGBW color values and the brightness values are converted into a DALI DT8 command sequence.</p>	<p>DALI - DT8 Color display: RGBWAF</p>
<p>Option 2:</p> <ul style="list-style-type: none"> • red: DPT 3.007 (B1U3) • green: DPT 3.007 (B1U3) • blue: DPT 3.007 (B1U3) • white: DPT 3.007 (B1U3) • Brightness: DPT_3.007 (B1U3) • Switching: DPT 1.001 (On/Off) 		<p>DALI - DT6 3(4)x1 channel DT6 / 3(4) channels 3(4) DALI addresses</p>

HSV color control

<p>Option 1:</p> <ul style="list-style-type: none"> • Hue: DPT 5.001 (0...100%) • Saturation: DPT 5.001 (0...100%) • Brightness: DPT_5.001 (0...100%) • Switching: DPT 1.001 (On/Off) 	<p>The HSV color values and the brightness values are first converted into RGB values and then into a DALI DT8 command sequence.</p>	<p>DALI - DT8 Color display: RGBWAF</p>
--	--	--

table 3 Standard Color Gates

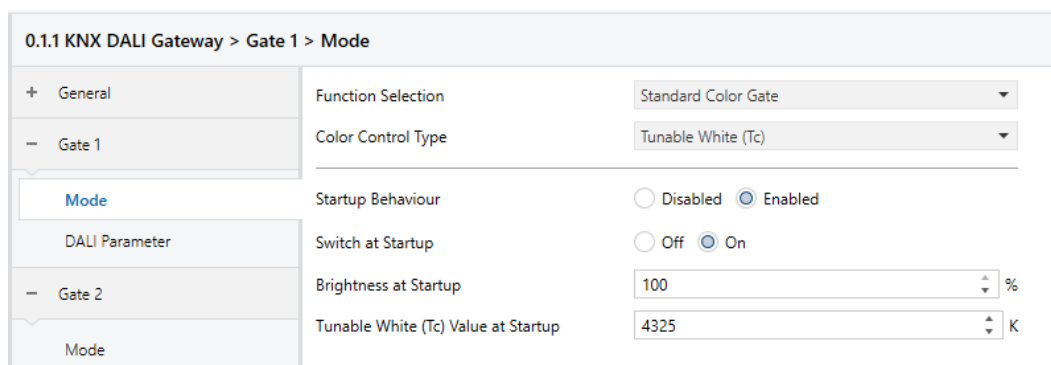

Fig.9 Gate Settings ETS: Tab „Mode“ Standard Color Gate for Tunable White

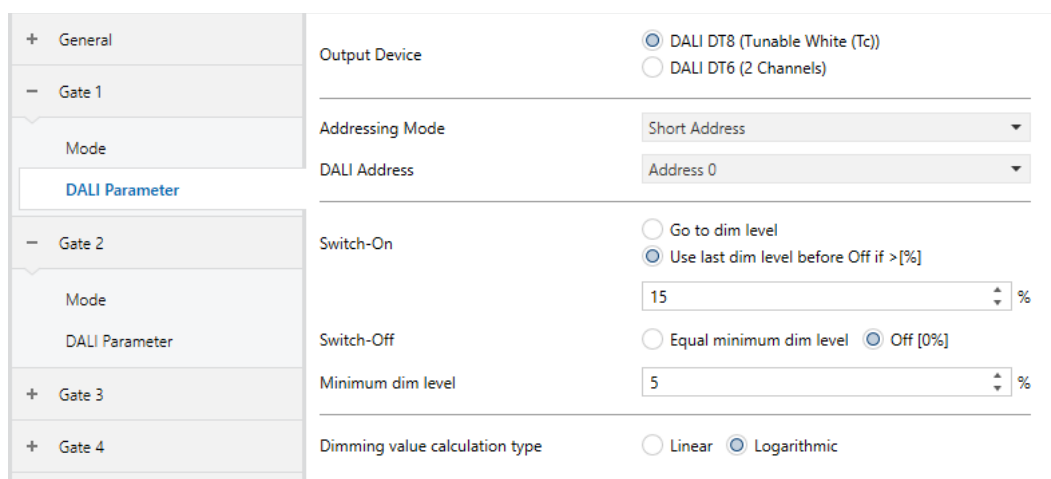

Fig.10 Gate Settings ETS: Tab „DALI Parameter“ Standard Color Gate

Scene Gates

DALI scenes can be recalled with KNX scene objects. Each of the 64 KNX scenes can be assigned to a DALI scene.



Control: Scenes

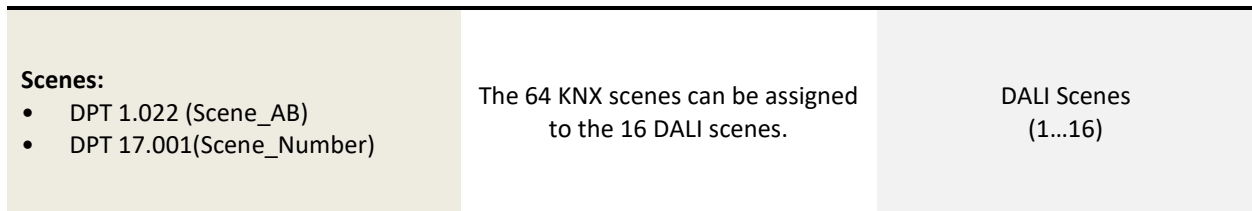

table 4 Scene Gates

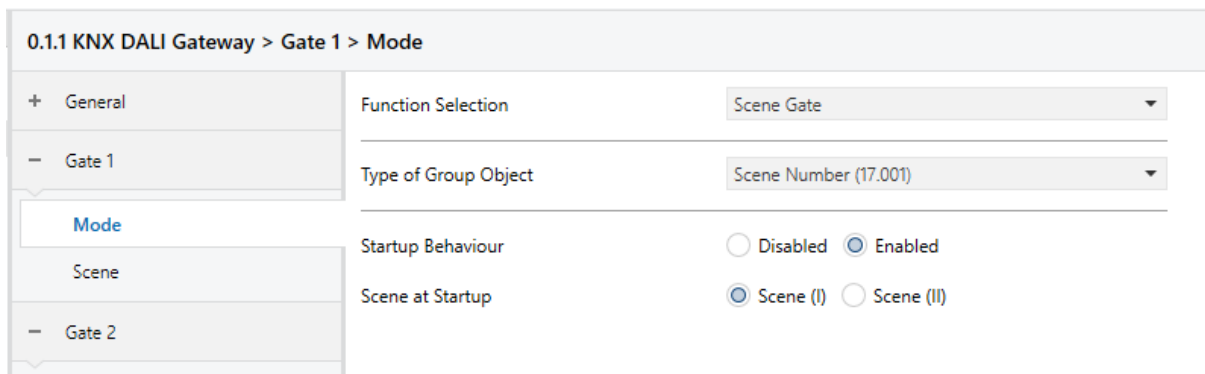

Fig.11 Gate Settings ETS: Tab "Mode" Standard Scene Gate

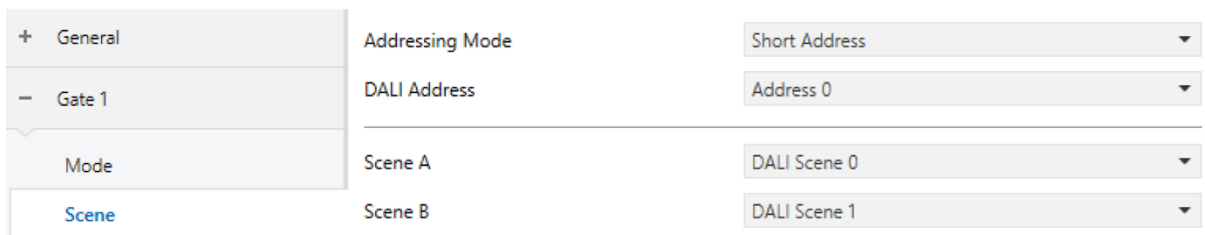



Fig.12 Gate Settings ETS: Tab „Scene“ Standard Scene Gate

Switch&Dim Gates

The gate type Switch&Dim offers the possibility to switch and dim lights.

 KNX control <i>(Modes, data point types)</i>	Gateway (notes)	 DALI device types (supported color modes)
--	-----------------	--

Control: Switch&Dim

<p>Option 1 - (absolute):</p> <ul style="list-style-type: none"> Brightness: DPT 5.001 (0..100%) Switching: DPT 1.001(On/Off) 	Other DALI device types can be controlled.	DALI - DT0 fluorescent lamps
		DALI - DT2 discharge lamps
		DALI - DT3 low voltage halogen lamps
<p>Option 2 - (relative):</p> <ul style="list-style-type: none"> Brightness: DPT 1.007 (incr./decr.) Switching: DPT 1.001(On/Off) 		DALI - DT4 incandescent light bulbs
		DALI - DT6 LED

table 5 Switch&Dim Gates

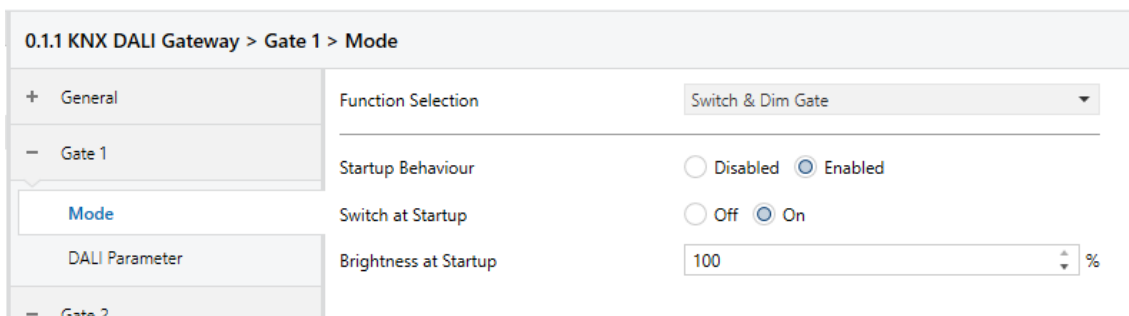

Fig.13 Gate Settings ETS: Tab „Mode“ Switch & Dim Gate

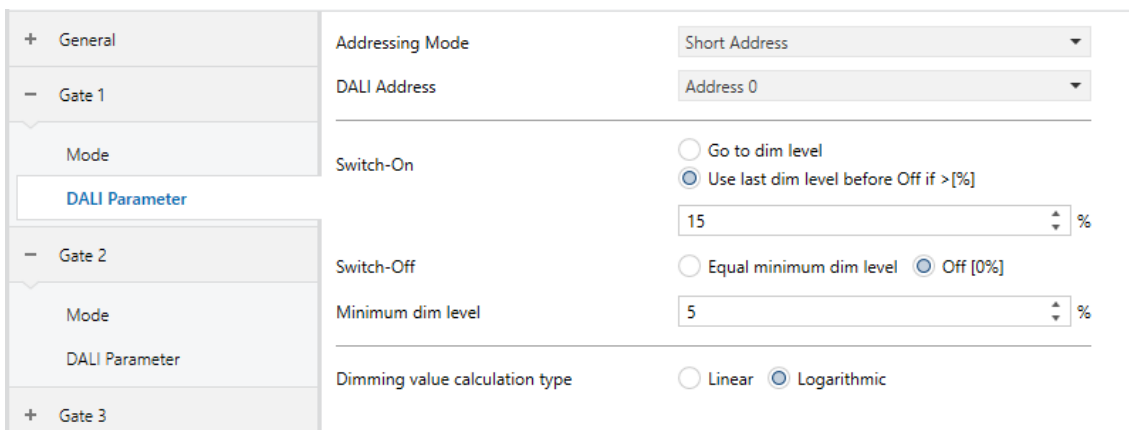

Fig.14 Gate Settings ETS: Tab „DALI Parameter“ Switch & Dim Gate

Sensor Event Gates

The gate type “Sensor Event Gate” enables the conversion of DALI-2 events to KNX.

The event information (10bit) is scaled by the gateway so that all common data point types can be supported. For Lunatone sensors the

conversion factors are stored in the gateway and can be easily selected. Manual scaling (universal) is possible via parameters.

The event filter can be used to filter events. All DALI-2 event schemes are supported

 <i>KNX data point types</i>			 <i>DALI instance type</i>		
Control: Events					
9.001	2-byte Float	°C	Temperature	Instance type 3 Lunatone sensor scaling	
9.002	2-byte Float	K			
14.068	4-byte Float	°C			
14.069	4-byte Float	K			
9.006	2-byte Float	Pa	Air pressure	Instance type 0 Lunatone sensor scaling	
14.058	4-byte Float	Pa			
9.007	2-byte Float	%	Rel. Humidity	Instance type 0 Lunatone sensor scaling	
9.008	2-byte Float	ppm	Air quality	Instance type 0 Lunatone sensor scaling	
203.100					
9.004	2-byte Float	Lux	Light intensity	Instance type 4 Lunatone sensor scaling	
5.010	8-bit unsigned	-	Universal	Alle instance types	
6.010	8-bit signed	-			
7.001	2-byte unsigned	-			
8.001	2-byte signed	-			
12.001	4-byte unsigned	-			
13.001	4-byte signed	-			

table 6 Event Gates

0.1.1 KNX DALI Gateway > Gate 1 > Mode

+ General	Function Selection	Sensor Event Gate
- Gate 1	Select category	Temperature
Mode	Type of Group Object	9.001
DALI Parameter	Select parameter set	<input checked="" type="radio"/> Lunatone <input type="radio"/> Custom
- Gate 2	Send cyclic	<input type="radio"/> No <input checked="" type="radio"/> Yes
Mode	Cycle time	0.25 s
DALI Parameter	Send on change	<input type="radio"/> No <input checked="" type="radio"/> Yes
+ Gate 3	Hysteresis	0
+ Gate 4		

Abb.15 Gate Settings ETS: Tab „Mode“ DALI-2 Event Gate

+ General	Event filter	
- Gate 1	DALI Event Scheme	Device
Mode	DALI Short Address	0
DALI Parameter	DALI Instance Type	0 (Generic purpose)
- Gate 2		

Abb.16 Gate Settings ETS: Tab „DALI Parameter“ DALI-2 Event Gate

Overview Gate types:

Gate type	KNX data point types Control	DALI DT8 Status	DALI DT6 Lunatone operation mode							
			xy-coordinates	RGBWAF	Tc	3(4) x DT6	2 x DT6	Colour&Dim	Balance&Dim	Dim2Warm
color / brightness separate	Option 1 - (absolute): Color: DPT 5.001 (0...100%) Brightness: DPT 5.001 (0...100%) Switching: DPT 1.001 (On/Off)	Color: DPT 5.001 (0...100%) Brightness: DPT 5.001 (0...100%) Switching: DPT 1.001 (On/Off) Lamp failure: DPT 1.002(False/True)	x	x		x		x		
	Option 2 - (relative): Color: DPT 1.007 (incr./decr.) Brightness: DPT 1.007 (incr./decr.) Switching: DPT 1.001 (On/Off)									
color temperature brightness separate	Option 1 - (absolute): Color: DPT 5.001 (0...100%) Brightness: DPT 5.001 (0...100%) Switching: DPT 1.001 (On/Off)	Color: DPT 5.001 (0...100%) Brightness: DPT 5.001 (0...100%) Switching: DPT 1.001 (On/Off) Lamp failure: DPT 1.002(False/True)	x		x		x		x	
	Option 2 - (relative): Color: DPT 1.007 (incr./decr.) Brightness: DPT 1.007 (incr./decr.) Switching: DPT 1.001 (On/Off)									
brightness, color automatic	Option 1 - (absolute): Brightness: DPT 5.001 (0...100%) Switching: DPT 1.001 (On/Off)	Brightness: DPT 5.001 (0...100%) Switching: DPT 1.001 (On/Off) Lamp failure: DPT 1.002(False/True)	x		x		x			x
	Option 2 - (relative): Brightness: DPT 1.007 (incr./decr.) Switching: DPT 1.001 (On/Off)									
XY color control	Option 1: Color x: DPT 7.001 (0..65.535) Color y: DPT 7.001 (0..65.535) Brightness: DPT 3.007 (B1U3) Switching: DPT 1.001 (On/Off)	Color x: DPT 7.001 (0..65.535) Color y: DPT 7.001 (0..65.535) Brightness: DPT 3.007 (B1U3) Switching: DPT 1.001 (On/Off) Lamp failure: DPT 1.002(False/True)	x							
	Option 2: Color xy: DPT 242.600 () Brightness: DPT 3.007 (B1U3) Switching: DPT 1.001 (On/Off)									
Tc color control	Option 1: Tc: DPT 7.600 (Color Temp.) Brightness: DPT 3.007 (B1U3) Switching: DPT 1.001 (On/Off)	Tc: DPT 7.600 (Color Temp.) Brightness: DPT 3.007 (B1U3) Switching: DPT 1.001 (On/Off) Lamp failure: DPT 1.002(False/True)	x					x		
	Option 2: Tc: DPT 5.001 (0...100%) Brightness: DPT 1.007 (incr./decr.) Switching: DPT 1.001 (On/Off)									
RGB color control	Option 1: red: DPT 5.001 (0...100%) green: DPT 5.001 (0...100%) blue: DPT 5.001 (0...100%) Brightness: DPT_3.007 (B1U3) Switching: DPT 1.001 (On/Off)	red: DPT 5.001 (0...100%) green: DPT 5.001 (0...100%) blue: DPT 5.001 (0...100%) Brightness: DPT_3.007 (B1U3) Switching: DPT 1.001 (On/Off) Lamp failure: DPT 1.002(False/True)		x		x				
	Option 2: red: DPT 3.007 (B1U3)									

	red: DPT 3.007 (B1U3) green: DPT 3.007 (B1U3) blue: DPT 3.007 (B1U3) Brightness: DPT_3.007 (B1U3) Switching: DPT 1.001 (On/Off)	green: DPT 3.007 (B1U3) blue: DPT 3.007 (B1U3) Brightness: DPT_3.007 (B1U3) Switching: DPT 1.001 (On/Off) Lamp failure: DPT 1.002(False/True)							
	Option 3: RGB: DPT 232.600 (Color RGB) Brightness: DPT 3.007 (B1U3) Switching: DPT 1.001 (On/Off)	RGB: DPT 232.600 (Color RGB) Brightness: DPT 3.007 (B1U3) Switching: DPT 1.001 (On/Off) Lamp failure: DPT 1.002(False/True)							
RGBW color control	Option 1: red: DPT 5.001 (0...100%) green: DPT 5.001 (0...100%) blue: DPT 5.001 (0...100%) white: DPT 5.001 (0...100%) Brightness: DPT_3.007 (B1U3) Switching: DPT 1.001 (On/Off)	red: DPT 5.001 (0...100%) green: DPT 5.001 (0...100%) blue: DPT 5.001 (0...100%) white: DPT 5.001 (0...100%) Brightness: DPT_3.007 (B1U3) Switching: DPT 1.001 (On/Off) Lamp failure: DPT 1.002(False/True)							
	Option 2: red: DPT 3.007 (B1U3) green: DPT 3.007 (B1U3) blue: DPT 3.007 (B1U3) white: DPT 3.007 (B1U3) Brightness: DPT_3.007 (B1U3) Switching: DPT 1.001 (On/Off)	red: DPT 3.007 (B1U3) green: DPT 3.007 (B1U3) blue: DPT 3.007 (B1U3) white: DPT 3.007 (B1U3) Brightness: DPT_3.007 (B1U3) Switching: DPT 1.001 (On/Off) Lamp failure: DPT 1.002(False/True)		x			x		
HSV color control	Option 1: Hue: DPT 5.001 (0...100%) Saturation: DPT 5.001 (0...100%) Brightness: DPT_5.001 (0...100%) Switching: DPT 1.001 (On/Off)	Hue: DPT 5.001 (0...100%) Saturation: DPT 5.001 (0...100%) Brightness: DPT_5.001 (0...100%) Switching: DPT 1.001 (On/Off) Lamp failure: DPT 1.002(False/True)							
	Option 2: Hue: DPT 3.007 (B1U3) Saturation: DPT 3.007 (B1U3) Brightness: DPT 3.007 (B1U3) Switching: DPT 1.001 (On/Off)	Hue: DPT 3.007 (0...360°) Saturation: DPT 3.007 (0...100%) Brightness: DPT 3.007 (0...100%) Switching: DPT 1.001 (On/Off) Lamp failure: DPT 1.002(False/True)						x	
Scenes	DPT 1.002 (Scene_AB) DPT 17.001(Scene_Number)	DPT 1.002 (Scene_AB) DPT 17.001(Scene_Number)							

table 7 Overview Gate types - control modes – device operating modes

Function overview DALI DT8 modes

The following color display modes are possible with DT8:

- xy coordinate
- Color temperature Tc
- Primary (color) N (not supported by GW)
- RGBWAF

 Attention: Not every DALI DT8 operating device supports all colors modes specified for DT8.

 Attention: When selecting the DT8 control units, make sure that the required modes are supported!

xy coordinate

In this mode, the color information can be transmitted to the luminaire in a standardized manner. The color adjustment is carried out via the X coordinate, the Y coordinate and the intensity.

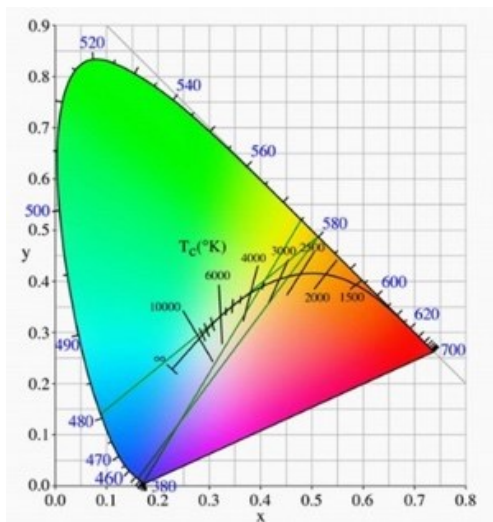

Color temperature Tc

With this mode, the color temperature is transmitted directly to the DALI operating device. Advantage: color temperatures are not calculated in the control unit. Color temperatures can be controlled relative to the initial value. Since the control gear is already

adjusted to the primary colors of the luminaire by the manufacturer, two-, three- or four-channel luminaires can be controlled.

A black body (perfectly radiant body) changes its color from red to yellow to white (Black-Body-Line - BBL) when its temperature rises. The absolute temperature T (Kelvin) of the black body is referred to as the color temperature T_c.



Primary (color) N

Each output channel (RGBW) is controlled individually. In this mode, the light output is determined by the sum of the individual channel outputs.

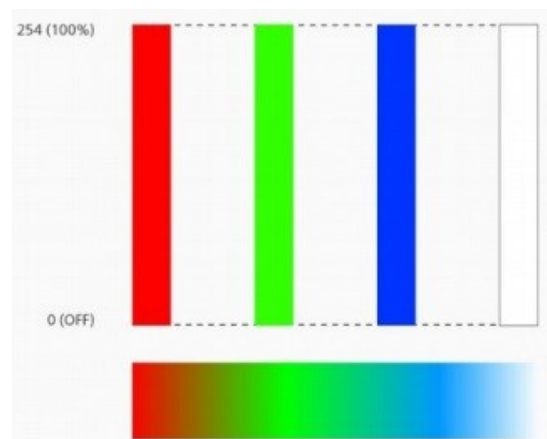

RGBWAF

With RGBWAF, up to a maximum of six output channels can be controlled independently of one another via the lamp power level. Each output channel is connected with an LED strip with e.g. a different color connected. The output channels must be assigned to the specific colors: R (red), G (green), B (blue), W (white), A (Amber) or F (freely selected color).

Lunatone Operating modes

As an alternative to the DT8 and DT6 control commands, the following operating modes can be used (via DALI as well as pushbuttons):

The operating mode can be set using the DALI Cockpit Software on the respective device page.

Operating mode: Colour&Dim

This operating mode offers an alternative to the DT8-RGBWAF mode:

DALI control:

Address 1 to control the brightness

Address 2 to control the color or indirect / direct lighting

SW&DIM2 control:

Button 1 (input SwD1) to control the brightness

Button 2 (input SwD2) to control the color or indirect / direct lighting

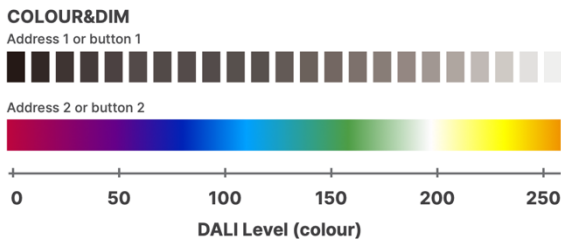

Operating mode: Balance&Dim

This control option offers an alternative to the DT8-Tc mode.

DALI control:

Address 1 to control the brightness

Address 2 to control the color temperature, or indirect / direct lighting

SW&DIM2 control:

Button 1 (input SwD1) to control the brightness

Button 2 (input SwD2) to control the color temperature or indirect / direct lighting



Operating mode: Dim2Warm

to control Tunable White luminaires

DALI control:

Only one address is required to control brightness and color temperature simultaneously; the lower the dimming value, the warmer the light.

SW&DIM2 control:

Only one button (input SW&DIM1) is required to control brightness and color temperature simultaneously; the lower the dimming value the warmer the light.

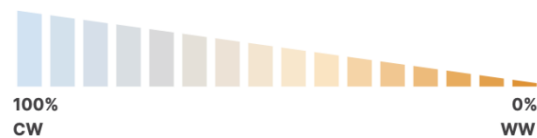

Purchase Information

Art.Nr.: 89453899 KNX DALI-2 Gateway: KNX to DALI and DALI to KNX gateway, fully multi-master capable, supports various color applications

Additional Information and Equipment

DALI Cockpit - free configuration software for DALI systems

<https://www.lunatone.com/en/product/dali-cockpit/>

Lunatone DALI products

<https://www.lunatone.com/en>

Lunatone datasheets and manuals

<https://www.lunatone.com/en/downloads-a-z/>

Contact

Technical Support: support@lunatone.com

Requests: sales@lunatone.com

www.lunatone.com



Disclaimer

Subject to change. Information provided without guarantee. The datasheet refers to the current delivery.

The function in installations with other devices must be tested for compatibility in advance.