

## 6-fold KNX pushbutton

Product code: EK-EB2-TP-...



Datasheet STEKEB2TP\_EN

KNX device for switching and control single loads or groups of loads. It has to be used in KNX installations for control of homes and buildings.

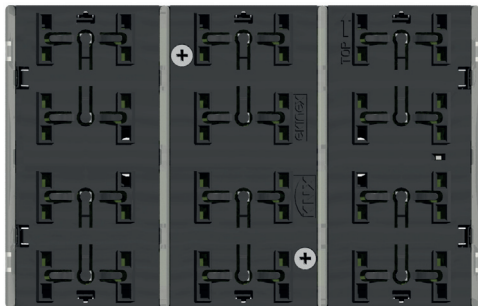

R/FL/EB2TP

### Description

The ekinex® 6-fold pushbutton (max 12 functions) is a S-mode KNX device for on/off switching of loads, dimming of lighting devices, controlling of motor drives or other programmable switching and control functions. It is equipped with an integrated KNX bus communication module and is designed for wall installation on flush mounting box. Each channel can be freely programmed for 1 or 2 bus functions and is provided with two LEDs configurable for example as a status signal or orientation nightlight. The pushbutton has to be completed with six rockers and a frame that must be ordered separately. Pushing a rocker, the device sends on the bus a telegram, which is received and executed by one or more KNX actuators. The device is powered by the KNX bus line with a SELV voltage 30 Vdc and does not require auxiliary power.

### Versions

The pushbutton is available with two combinations of colours for the LEDs (blue/green and red/white).

Code	LED colours	Mounting
EK-EB2-TP	blue / green	with rectangular frame, form or flank series
EK-EB2-TP-RW	red / white	



**Note.** Rockers and frame for the completion of the device must be ordered separately. For more information on materials, colors and finishes available, see also the ekinex® product catalog or browse [www.ekinex.com](http://www.ekinex.com)

### Main functional characteristics

- On/off switching of single loads or groups of loads
- Dimming of lighting devices
- Control of motor drives (for roller shutters, blinds, curtains, etc.)
- Recalling and saving of scenes

- Sending on the bus of values (temperature, brightness, etc.)
- Switching to forced functioning (lock)
- Measuring of room temperature and light brightness through integrated sensors
- Different functions programmable for short pressure / long pressure of a rocker
- Status feedback or orientation nightlight through 2-color programmable LEDs

### Other characteristics

- Housing in plastic material
- Wall installation in flush mounting box
- Protection degree IP20 (according to EN 60529)
- Classification climatic 3K5 and mechanical 3M2 (according to EN 50491-2)
- Pollution degree 2 (according to IEC 60664-1)
- Weight 55 g (75 g with mounting support)
- Dimensions 122 x 78 x 35 mm (WxHxD)

### Technical data

- Power supply 30 Vdc from KNX bus line
- Current consumption < 15 mA
- Power from bus < 360 mW

### Environmental conditions

- Operating temperature: - 5 ... + 45°C
- Storage temperature: - 25 ... + 55°C
- Transport temperature: - 25 ... + 70°C
- Relative humidity: 95% not condensing

### Completion of the pushbutton



Device completed with EK-FLR-... (flank) frame and EK-TSQ-... rockers



Device completed with EK-FOR-... (form) frame and EK-TSQ-... rockers





For installation and operation an ekinex® pushbutton must be completed with a separate order of:

- operation elements consisting of six square rockers;
- one rectangular frame of the ekinex® form or flank series.

Rockers and frames are available in plastic or metal versions. The metallic support, the fixing screws (two pairs) and the KNX terminal block for connection of the bus line are supplied with the device.

## Rockers

Three-positions rockers with central neutral position have to be mounted on the pushbutton. Pushing one side of a rocker (for example the upper one), the pushbutton sends on the bus a telegram for switching on, increasing the brightness of luminaires or raising the blinds, while pushing the other side (for example the lower one), it sends a telegram for switching off, reducing the brightness of luminaires or lowering the blinds. Each channel is equipped with LEDs which can be freely programmed as status feedbacks of the loads and as orientation nightlight.

Code *	Material	Package	Modularity [mm]
EK-TSQ-GAx	plastic		4 pcs. square 40 x 40
EK-TSQ-GBx	metal		
EK-TSR-GAx	plastic		4 pcs. rectangular 80 x 20
EK-TSR-GBx	metal		

(\*) It has to be completed with the extension for the colour choosed (x)





**Note.** The application program allows to configure the pushbutton with a combination of square and rectangular rockers. For the allowed combinations see the application manual or the application program for ETS.

### Customization of rockers

The rockers can be customized with symbols and texts, for more information see the standard library on the ekinex® catalog or the website [www.ekinex.com](http://www.ekinex.com). On request it is also possible a customization with symbols and texts chosen by the customer.

### Frame

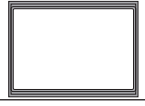
The device is completed with a rectangular frame of the form (EK-FOR-...) or flank (EK-FLR-...) series.

Code *	Material	Package	Dimens. [mm]
EK-FOR-GAx	plastic		1 pcs. 126 x 86
EK-FOR-GBx	metal		
EK-FLR-GAx	plastic		1 pcs. 135 x 80
EK-FLR-GBx	metal		

(\*) It has to be completed with the extension for the colour (x)

### Mounting

The device has degree of protection IP20, and is therefore suitable for use in dry interior rooms. The installation of the device requires the following steps:

- fix the metallic support (5) with the screws supplied (6) on the wall box (7) provided with suitable fixing holes;
- snap a rectangular frame (4) of the form or flank series, inserting it from the rear of the device (3);
- enter the bus terminal, previously connected to the bus cable in its slot on the rear side (see also: "Connection of the KNX bus line"). At this point it is recommended to carry out the commissioning of the device (see also "Configuration and commissioning") or at least the download of the physical address;

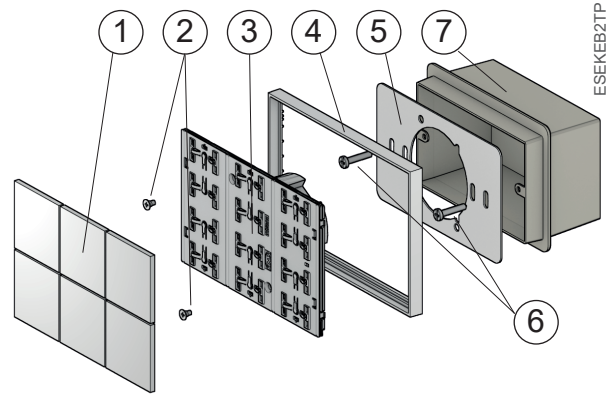

- 1) Rockers (to be ordered separately)
- 2) Screws to fasten the pushbutton on the metallic support
- 3) 6-fold pushbutton
- 4) Frame of the series form or flank (to be ordered separately)
- 5) Metallic support for mounting wall box
- 6) Screws for fixing the support on the wall box
- 7) Flush-mounting box

d) mounting the device (3) on the metallic support supplied (5) with the screws (2). The correct mounting of the device occurs when the bus terminal is located in the lower part; for mounting the device follow also the indication TOP (arrow tip pointing up) on the rear side of the device.

e) snap the six rockers (1) on the device.

The 6-fold pushbutton can be mounted on a round or a square (60 mm hole centres) or a rectangular (83,5 mm hole centres) flush-mounting box. If necessary, the metallic support for mounting on the wall box can also be ordered separately using the code EK-SMR.

### Mounting of rockers

For the mounting of the rockers on the dedicated seats, the fixing elements must be aligned vertically.

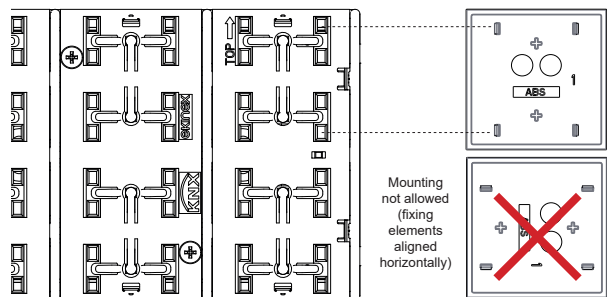

### Switching, display and connection elements

The device is equipped with mechanisms for switching, 2 LEDs for each channel, a programming LED and a programming pushbutton and a terminal block for connection of the bus line.

#### Switching elements

- Pushbutton (3) for switching between the normal and programming operating mode
- Mechanisms (4) for independent switching of single or group of loads (to be completed with square rockers)

#### Display elements

- Red LED (2) for indication of the active operating mode (on = programming, off = normal operation)
- Freely programmable LEDs with lightguide e.g. for feedback status and orientation nightlight



**Note.** Programming pushbutton and LED are only accessible from the rear side of the device. It is better addressing the device before the final assembly of rockers and frame. Once the addressing has been performed, the device configuration can be later downloaded without pressing the programming pushbutton.

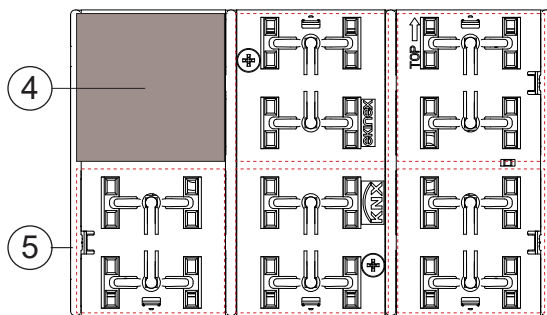
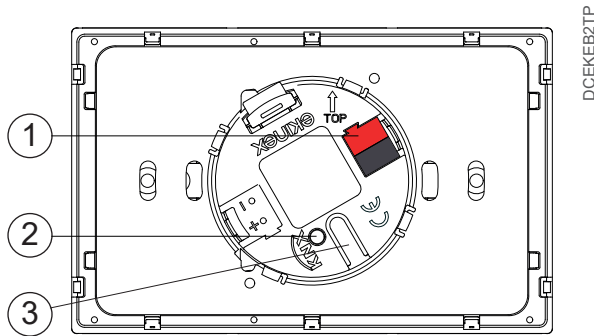

- 1) Connection terminal block for KNX bus line
- 2) Programming LED
- 3) Programming pushbutton
- 4) Rocker
- 5) Lightguide for LED



**Warning!** The electrical connection of the device can be carried out only by qualified personnel. The incorrect installation may result in electric shock or fire. Before making the electrical connections, make sure the power supply has been turned off.

### Connection of the KNX bus line

The connection of the KNX bus line is made with the terminal block (black/red) included in delivery and inserted into the slot of the housing.

#### Characteristics of the KNX terminal block

- spring clamping of conductors
- 4 seats for conductors for each polarity
- terminal suitable for KNX bus cable with single-wire conductors and diameter between 0.6 and 0.8 mm
- recommended wire stripping approx. 5 mm
- color codification: red = + (positive) bus conductor, black = - (negative) bus conductor



**Warning!** In order to supply the KNX bus lines use only KNX bus power supplies (e.g. ekinex EK-AB1-TP or EK-AG1-TP). The use of other power supplies can compromise the communication and damage the devices connected to the bus.

### Configuration and commissioning

Configuration and commissioning of the device require the use of the ETS® (Engineering Tool Software) program V4 or later releases. These activities must be carried out according to the design of the building automation system done by a qualified planner.

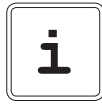

**Note.** The configuration and commissioning of KNX devices require specialized skills. To acquire these skills, you should attend the workshops at KNX certified training centers.

### Configuration

For the configuration of the device parameters the corresponding application program or the whole ekinex® product database must be loaded in the ETS program. For detailed information on configuration options, refer to the application manual of the device available on the website [www.ekinex.com](http://www.ekinex.com).

Product code	Application program (## = release)	Communication objects (max nr.)	Group addresses (max nr.)
EK-EB2-TP	APEKEB2TP##.knxprod	232	232

### Commissioning

For commissioning the device the following activities are required:

- make the electrical connections as described above;
- turn on the bus power supply;
- switch the device operation to the programming mode by pressing the programming pushbutton located on the rear side of the housing. In this mode of operation, the programming LED is turned on;
- download into the device the physical address and the configuration with the ETS® program.

At the end of the download the operation of the device automatically returns to normal mode; in this mode the programming LED is turned off. Now the bus device is programmed and ready for use.

### Dimensions [mm]

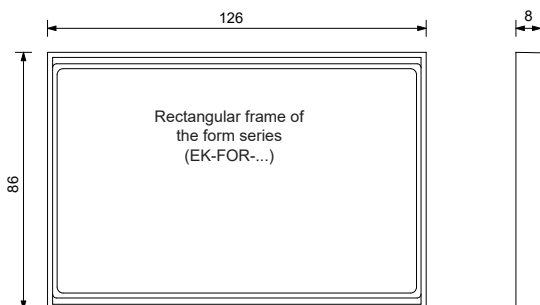
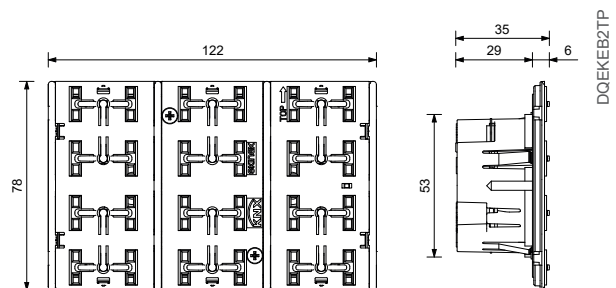

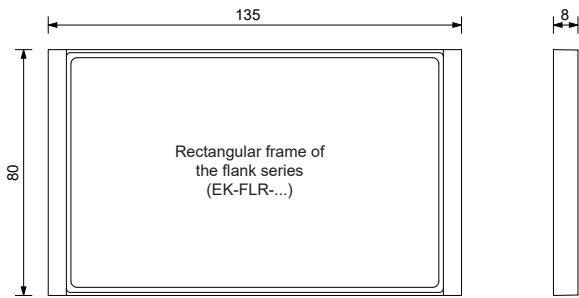

- For further information on the product, please contact the ekinex® technical support at the e-mail address: support@ekinex.com or visit the website www.ekinex.com
- Each ekinex® device has a unique serial number on the label. The serial number can be used by installers or system integrators for documentation purposes and has to be added in each communication addressed to the EKIENX technical support in case of malfunctioning of the device
- KNX® and ETS® are registered trademarks of KNX Association cvba, Brussels

© EKINEX S.p.A. The company reserves the right to make changes to this documentation without notice.

### Marks

- KNX
- CE: the device complies with the Low Voltage Directive (2006/95/EC) and the Electromagnetic Compatibility Directive (2004/108/EC). Tests carried out according to EN 50491-5-1:2010, EN 50491-5-2:2010

### Maintenance

The device is maintenance-free. To clean use a dry cloth. It must be avoided the use of solvents or other aggressive substances.

### Disposal



At the end of its useful life the product described in this datasheet is classified as waste from electronic equipment in accordance with the European Directive 2002/96/EC (WEEE), and cannot be disposed together with the municipal undifferentiated solid waste.



**Warning!** Incorrect disposal of this product may cause serious damage to the environment and human health. Please be informed about the correct disposal procedures for waste collecting and processing provided by local authorities.

### Documentation

This datasheet refers to the release A1.0 of the ekinex® device EK-EB2-TP, and is available for download at www.ekinex.com as a PDF (Portable Data Format) file.

File name	Device release	Updating
STEKEB2TP_EN.pdf	A1.0	07 / 2015

### Warnings

- Installation, electrical connection, configuration and commissioning of the device can only be carried out by qualified personnel in compliance with the applicable technical standards and laws of the respective countries
- Opening the housing of the device causes the immediate end of the warranty period
- In case of tampering, the compliance with the essential requirements of the applicable directives, for which the device has been certified, is no longer guaranteed
- ekinex® KNX defective devices must be returned to the manufacturer at the following address: EKINEX S.p.A. Via Novara 37, I-28010 Vaprio d'Agogna (NO) Italy

### Other information

- This datasheet is aimed at installers, system integrators and planners



EK-EB2-TP

### Direct access to device documentation

The QR code allows the direct access to the technical documentation of ekinex® EK-EB2-TP using mobile devices (smart phones, tablets) with a standard QR code reader.